

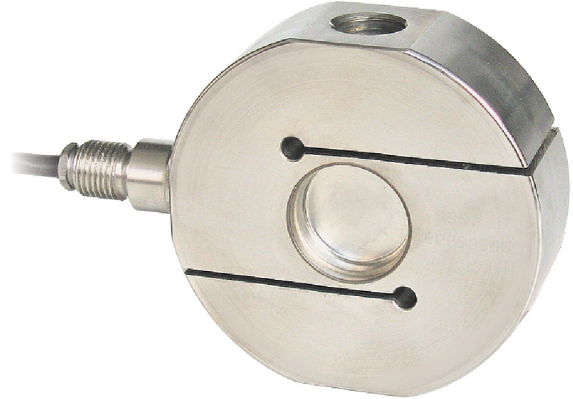

## Capacity from 100 kg to 12500 kg



- 17-4 PH STAINLESS STEEL
- COMBINED ERROR  $\leq \pm 0.02\%$
- PROTECTION CLASS IP68

CAPACITY	kg	ACCURACY CLASS C3					NET WEIGHT (kg)	CODE
100		-	-	•	•	•	0.7	CTL100
200		-	-	•	•	•	0.7	CTL200
300		-	-	•	•	•	0.7	CTL300
500		•	•	•	•	•	1.4	CTL500
1000		•	•	•	•	•	1.4	CTL1000
2500		•	•	•	•	•	1.4	CTL2500
5000		•	•	•	•	•	2.6	CTL5000
7500		•	•	•	•	•	2.7	CTL7500
10000		•	•	•	•	•	3.7	CTL10000
12500		•	•	•	•	•	4.8	CTL12500

ON REQUEST

### CERTIFICATIONS

- OIML R60 C3
- Complies with the Eurasian Custom Union standards

#### CERTIFICATIONS ON REQUEST

- Declaration of conformity + IP69K marking protection rating  
*Water protection in case of high-pressure or steam jet cleaning (test: pressurized water is sprayed from a distance of max 150 mm)  
Water pressure: 100 bar; temperature: 80 °C; test duration: 250 seconds (reference standard: DIN 40050-9)*
- Accredia traceable calibration report
- ATEX II 1GD (zone 0-1-2-20-21-22)
- IECEx (zone 0-1-2-20-21-22)
- Complies with the Eurasian Custom Union standards for use in potentially explosive atmospheres
- Complies with the regulations of the Russian Federation for legal for trade use

### OPTIONS ON REQUEST

#### DESCRIPTION



Two redundant strain gauges Wheatstone bridges (350 Ω) with two output cables; for dual safety systems.

### COMPLEMENTARY ACCESSORIES

	DESCRIPTION	DIMENSIONS	LOAD CELL CAPACITY	CODE
	Ball-and-socket joint with nut:			
	stainless steel	M12x1.75	100-300 kg	EM12DADOINOX
		M16x2	500-1000 kg	EM16DADOINOX
		M20x1.5	2500 kg	EM20DADOINOX
		M24x2	5000-7500 kg	EM24DADOINOX
	C45 special steel	M12x1.75	100-300 kg	EM12DADO
		M16x2	500-1000 kg	EM16DADO
		M20x1.5	2500 kg	EM20DADO
		M24x2	5000-7500 kg	EM25DADO
		M30x2	10000 kg	EM30DADO
M36x3		12500 kg	EM35DADO	

### DIMENSIONS (mm)

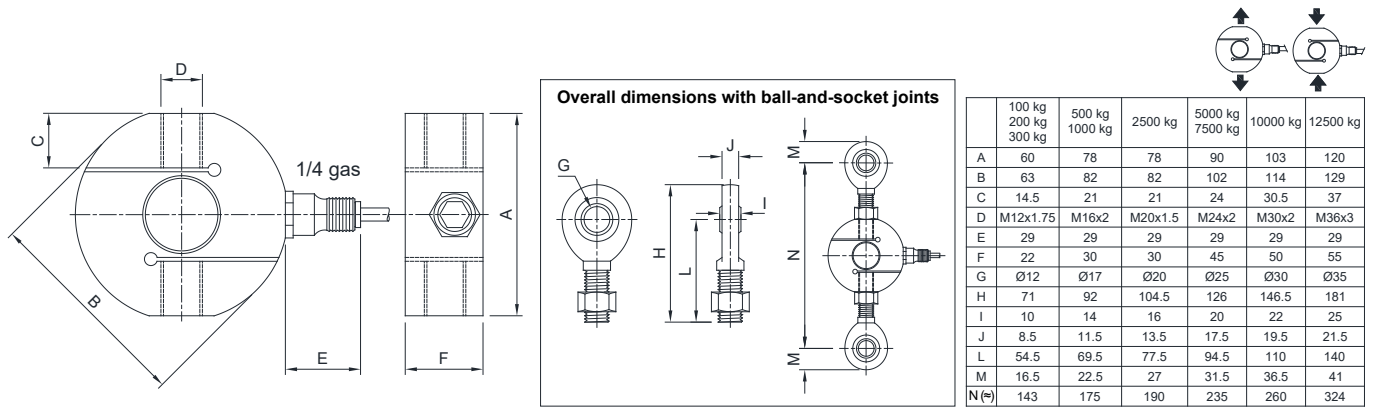

### TECHNICAL FEATURES

Material	17-4 PH stainless steel		
OIML R60 Accuracy class • Verification intervals	-		C3 • 3000
Nominal load (E max)	100 - 200 - 300 kg		500 - 1000 - 2500 - 5000 kg 7500 - 10000 - 12500 kg
Minimum verification interval (V min)	E max / 10000		
Combined error	≤ ±0.02%		
Protection class	IP68		
Rated output	2 mV/V ±0.1%	Input resistance	350 Ω ±5
Temperature effect on zero	0.005% °C	Output resistance	350 Ω ±2
Temperature effect on span	0.003% °C	Zero balance	±1%
Compensated temperature range	-10 °C / +50 °C	Insulation resistance	≥5000 MΩ
Operating temperature range	-20 °C / +70 °C	Safe overload (% of full scale)	150%
Creep at nominal load in 30 minutes	0.05%	Ultimate overload (% of full scale)	300%
Max supply voltage without damage	15 V	Deflection at nominal load	0.3 mm

### ELECTRICAL CONNECTIONS

Cable length	10 m
Cable diameter	5 mm
Cores	6 x 0.14 mm <sup>2</sup>

